



Milan - Central Division - First Instance -

UPC_CFI_380/2024
Final Order
of the Court of First Instance of the Unified Patent Court
delivered on 22/11/2024

APPLICANT/S

Insulet Corporation
(Claimant) - 100 Nagog Park - MA 01720 -
Acton – US - Represented by Marc Grunwald

RESPONDENT/S

EOFLOW Co., Ltd.
(defendant) - 302Ho, HUMAX VILLAGE, 216 – 13595
- Hwangsaedul-ro, Bundang-gu, Seon - Represented by Mirko Weinert

PATENT AT ISSUE

<i>Patent no.</i>	<i>Proprietor/s</i>
-------------------	---------------------

EP4201327	Insulet Corporation
------------------	---------------------

DECIDING JUDGE

COMPOSITION OF PANEL – FULL PANEL

Presiding judge	Andrea Postiglione
Judge-rapporteur	Andrea Postiglione
Legally qualified judge	Anna-Lena Klein
Technically qualified judge	Uwe Schwengelbeck

LANGUAGE OF PROCEEDINGS: English

SUBJECT-MATTER OF THE PROCEEDINGS (main proceedings: application of provisional measure)

Headnotes:

In the proceedings for provisional measures, the Applicant is required to provide cumulatively reasonable evidence to satisfy the Court with sufficient degree of certainty that: (i) the Applicant is entitled to initiate proceedings under Art. 47 UPCA; (ii) the patent is valid; (iii) its rights are being infringed or that such infringement is imminent (Rule 211.2 RoP).

The auxiliary request to amend the patent pursuant to Rule 30.2 RoP is not admissible in the proceedings for provisional measures, in accordance with the necessary expediency of the procedure, that requires the imminence of the prejudice and, at the same time, the necessity to respect the adversarial principle and the right of defense.

The phrase “amend its case” in Rule 263.2 RoP refers to the pleadings amendments (“change its claim”) and does not relate to patent amendments pursuant to Rule 30 or 50.2 RoP.

Keywords:

Claim interpretation, Rule 263 RoP; Rule 30.2 RoP,

ORDER

Summary of the procedural facts

On 3 July 2024 INSULET Co. (the applicant) filed an *ex parte* application for a preliminary injunction requesting the Court:

to ORDER EOFLOW co. Ltd (the defendant in the suit)

- to refrain from manufacturing, offering, placing on the market, using or possessing, for the purposes mentioned, or from importing or storing the product for such purposes in the territories of the Member States of the Unified Patent Court ‘a fluid dispensing device comprising: a fluid reservoir, a transcutaneous access tool fluidly coupled to the fluid reservoir and a drive mechanism for dispensing fluid from the fluid reservoir, the drive mechanism comprising: a drive wheel, a plunger received in the fluid reservoir and a lead screw extending from the plunger, characterized in that the drive mechanism also comprises a threadable nut engaged with the drive screw and a clutch coupled to the drive wheel, wherein the clutch is configured to allow the nut to pass through the clutch when disengaged and is configured to grip the nut when engaged such that the drive wheel rotates the nut to advance the drive screw and plunger into the reservoir’,

- to provide the applicant's counsel, within 4 weeks of notification of the order issued in this matter, with a written statement, supported by appropriate documentation, concerning: the origin and distribution channels of the infringing devices referred to in I.1 within the UPC Contracting Member States (including the full names and addresses of the legal entities concerned) the quantities

delivered, received or ordered, as well as the price obtained for the devices in the UPC Member States and the identity of any party involved in the production or distribution of the devices referred to in the UPC Member States (including the names and full addresses of the legal persons involved).

INSULET Co. (INSULET in the suit) is a medical device company based in the United States. The applicant claims to have developed and sold, inter alia, 'Omnipod5', a disposable, wearable, tubeless insulin management system that allows automatic insulin delivery (a so-called insulin pump).

EOFLOW Co. Ltd. (EOFLOW in the suit) is a medical device developer and manufacturer based in South Korea. The Defendant manufactures the 'EOPatch' insulin pump, marketed in Europe under the trade name 'GlucoMen Day Pump'.

INSULET is the undisputed owner of the patent EP4201327C0, which is based on a divisional application in the patent family of PCT application WO 2013/149186 A1 (filed 29 March 2013; priority date: 30 March 2012). The grant of the patent was published on 19 June 2024. The unitary effect of the patent at issue was recorded in the Register for Unitary Patent Protection on 23 June 2024. There has been filed no opposition yet. EOFLOW has instead filed with this Court a revocation action on the merits during these proceedings.

The invention covered by the patent at issue pertains to a fluid delivery device, specifically intended for the delivery of therapeutic liquids such as insulin for diabetic patients.

INSULET maintains that insulin pumps were already known in the prior art as devices for supplying a diabetic patient with certain amounts of insulin throughout the day. Such pre-existing insulin pumps were commonly referred to as 'tubed' pumps because they were connected to the patient via a long tube through which the insulin was delivered from the pump into the patient's body. Nevertheless, these insulin pumps had several disadvantages, being expensive, complex, heavy, and cumbersome to operate, which made it difficult to perform normal activities with them.

By contrast, INSULET's 'patch pump' is attached directly to the user's body using an adhesive attached to its underside. The applicant's pumps are much smaller and operate without a tube attached outside the housing delivering insulin from the pump directly into the user's body.

The inventive step as identified by INSULET lies in the development of a 'fluid delivery device such that filling its reservoir is simple while changing the device into a state for delivering fluid to a patient is efficient and reliable'.

The applicant asserts that EOFLOW's embodiment falls entirely within the scope of EP4201327C0. After obtaining samples of the insulin pump "EOPatch" INSULET appointed a technical expert Mr. Ian Mclaughlin, who proceeded to analyze and test the samples (Exhibit 10) bringing to light significant similarities between the two embodiments.

As historical context INSULET points out that an injunction based on the German part of EP 1 874 390 B1 was previously issued against the German distributor BERLIN-CHEMIE AG / Division A. Menarini Diagnostics (Deutschland) (BERLIN-CHEMIE AG) with the Düsseldorf District Court on 27 February 2023 (Docket No. 4c O 10/23).

BERLIN-CHEMIE AG is part of the Menarini Group and was responsible for the exclusive distribution of the allegedly infringing embodiment in Germany.

MENARINI Diagnostics s.r.l. is undisputedly the main distributor of EOPATCH in Europe. Despite this, MENARINI – as stated by INSULET - issued a cease-and-desist declaration to INSULET invoking the German part of EP 1 874 390 B1, precluding any distribution of EOPATCH within German territory.

INSULET filed a request for Preliminary Injunction (PI) also in the USA, which was initially successful and reportedly only overturned on appeal due to a technical issue. Nevertheless, in a letter dated 13 November 2023, MENARINI informed its customers of his intention to stop selling the EOPATCH embodiment, citing the US case concerning the PI.

Regarding the *ex parte* request, INSULET maintained that the injunction should be issued urgently, emphasizing a press release from MENARINI dated 24 May 2024 which announced the resumption of distribution of EOPATCH in UPC Member States including Belgium, Luxembourg, Sweden and the Netherlands.

INSULET pointed out that as soon as the applicant has obtained all the necessary knowledge and documents to initiate a legal action, it filed the application for provisional measures with a reasonable timeframe (one month) thereby fulfilling the requirement of Rule 206 RoP.

INSULET has duly reported on the prior correspondence between the parties as well as on the legal actions filed in the USA and in Germany.

Regarding irreparable harm, INSULET argues that the distribution of EOPATCH would negate 20 years of work and investment causing a damage that could scarcely be remedied by the outcome of the infringement proceedings. The development of the Applicant's insulin pump required hundreds of millions of dollars in investments placing EOFLOW in the position to undercut the applicant by offering lower prices to government agencies, insurance companies and private payers (see exhibit 17 'Cyprus tenders').

The *ex parte* application was denied by this Court.

In an order dated 8th July '24 the court noted: *"The Court preliminarily observes that, subject to further discussion, there are no elements, as outlined in art. 62 UPCA, indicative of patent invalidity. The Court observes furthermore that the patent was granted some weeks before the request and has not undergone contradictory validity proceedings. However, these factors do not a priori conflict with issuing a preliminary injunction. In the absence of such contradictory proceedings on validity, the Court might still find reasonable to consider the patent in question as valid (see UPC_CFI 452-23), also in light of the burden of proof of the invalidity in contradictory proceedings, including provisional measures, which lies with the defendant. It should also be borne in mind that under Rule 62 UPCA 'The Court shall have the discretion to weigh up the interests of the parties and in particular to take into account the potential harm for either of the parties resulting from the granting or the refusal of the injunction'. This applies even if the defendant has not lodged a statute of defense yet. The issuance of ex parte measures cannot therefore be based solely on the claimant's submissions, but*

requires an assessment, albeit prospective and speculative, into the defendant's possible lines of defense, its interests, and its imaginable prejudice”.

EOFLOW lodged a defense (including a request pursuant to Rule 262A) asserting that the precautionary grounds put forward by INSULET were baseless, that the patent was invalid in light of prior art references US 2009/0124994 A1201261618028 (ROE) and WO 2010/055504 A1 (YODFAT) and that - furthermore - the patent was not sufficiently disclosed, particularly regarding the assembly of the invention, the term “nut” which was subject to different interpretations, the extension of the threaded part of the screw, the clutch features an other elements)¹.

As regards urgency, EOFLOW stipulated that no invasion of the market could occur in a short period of time – certainly not within one year, the timeframe which the Court imposes on itself for issuing a decision on the merits; it emphasizes the fact that the two products were (or would be) sold at comparable market prices. It compared the appellant's business model and market share to its own (0.25%) and pointed out that there were no immediate market-risks for INSULET arguing that there was no possibility of a future duopoly, at least not in the short term.

Finally, EOFLOW concluded that no interim measure was necessary for Germany. In fact, the defendant's exclusive distributor for Europe, Menarini, had already issued a cease-and-desist declaration for Germany with respect to the challenged embodiments.

An injunction, as filed by the counterpart, would - on the contrary - cause irreparable harm to EOFLOW's market share and reputation.

¹ A. We request: A. The Applicant’s application for provisional measure is rejected. II. The Applicant shall bear the costs of the proceedings.

B. In the alternative to A., allow Defendant to continue the alleged infringing activities subject to provision of security by Defendant, the amount of which to be determined by the Court.

C. In the alternative to B., to apply to any preliminary injunction ordered against the Defendant the provision that I. the territories of Austria, Bulgaria, Denmark, Estonia, Finland, France, Germany, Latvia, Lithuania, Luxembourg, Malta, Portugal and Slovenia are excluded from the geographical scope of this preliminary injunction; and II. the Defendant is allowed to continue – if the Court deems appropriate subject to provision of security by Defendant, the amount of which to be determined by the Court – to supply Menarini with the attacked embodiments to ensure that Menarini may continue to supply the attacked embodiments to public and private hospitals and health care providers under tenders awarded to Defendant before the service of the application for provisional measures;

D. in the alternative to C., I. the Defendant is allowed to continue – If the Court deems appropriate subject to provision of security by Defendant, the amount of which to be determined by the Court – to supply Menarini with the attacked embodiments to ensure that Menarini may continue to supply the attacked embodiment to patients to whom the attacked embodiment was prescribed prior to the date of service of the application for provisional measures for at least six months of the date of the decision of the Court; and II. the Defendant is allowed to continue – if the Court deems appropriate subject to provision of security by Defendant, the amount of which to be determined by the Court – to supply Menarini with the attacked embodiments to ensure that Menarini may continue to supply the attacked embodiment to patients who have been prescribed the attacked embodiment before the date of service of the application for provisional measures and have been certified by an diabetologist to not be able to use an insulin pump different from the attacked embodiment indefinitely;

E. in the alternative, in any event where the Court orders a preliminary injunction, order Applicant to provide a security by for the enforcement of a preliminary injunction and/or other provisional measure, the amount to be determined by the Court, whereas the security should not fall below EUR 2,500,000.

INSULET also filed a PI request also with the LD Milan, against the aforementioned EOPATCH's main distributor MENARINI s.p.a.

On 26 August 2024 EOFLOW filed a request for a Connection Joinder (Rule 340 RoP) between the two cases, which was rejected by the Court by order of 4 September 2024. The Court determined that handling both cases in parallel with an adapted timeline and the assignment of the same TQJ and LQJ to both panels would limit the risk of divergent decisions. A subsequent application for review of this order (RoP 333) was also rejected.

On 16 September 2024 MENARINI filed then an application to intervene in these proceedings asserting that a decision in the present case would affect its interests regarding the contractual relationship with the Defendant (the manufacturer of the attacked embodiments, i.e. upstream) and its contractual relationships with its customers (i.e. downstream).

EOFLOW supported the request for intervention with written submissions.

This Court rejected the request by Order of 1 October 2024 stating *"First, Menarini can sufficiently achieve its objectives in the parallel proceedings and should be given no double possibility to represent the case in front of two different Courts. Moreover, pursuant to Art. 313 RoP intervention is allowed to a third party having its own interest not merely factual but legal. The third party must therefore present itself as the owner of a legal relationship connected with the one brought in litigation by the counterpart or dependent on it and the connection must entail a total or partial impairment of the right of which the third party claims to be the owner in the event the original party loses the case; that is to say, it is necessary to be the owner of a substantial situation connected with the relationship brought in litigation, such as to expose the third party to the reflexive effects of the judgement. In this case, however, the legal interest of MENARINI is already granted by way of defense in the parallel proceedings in front of UPC Milan Local Division. Furthermore, the defendants have already tried to avoid parallel proceedings by filing a request of joinder, rejected both by the Judge rapporteur and the panel"*.

The parties submitted written submissions and presented extensive arguments at the hearing, which took place at the Court's seat in Milan CD on 16 October 2024.

As a result, the Court reserved the right to issue an order by 20 November 2024.

The Preliminary Injunction cannot be granted.

The Court has already confirmed the admissibility of the application for a preliminary injunction in accordance with the formal requirements laid down in Rules 206 and 207 RoP in its order of 8 July 2024.

On the merits, the requirements for the grant of a preliminary injunction are clearly set out in Rule 211 RoP, which provides that *'in taking its decision the court may require the applicant to provide reasonable evidence to satisfy the Court with a sufficient degree of certainty that the applicant is*

entitled to commence proceedings pursuant to Rule 47, that the patent in question is valid and that his right is being infringed or that such infringement is imminent'.

This Court is therefore called upon to rule on both infringement and validity, the latter following the defendant's challenge to the validity of the patent.

While the assessment of possible infringement logically precedes in a PI proceeding the assessment of the validity of the patent, the Court deems it necessary and appropriate in this very case to first assess the validity of the patent.

There are a several reasons for this: the first and most obvious relates to speed and procedural efficiency. Examining the correspondence between the two products becomes, in fact, superfluous if there are concrete elements suggesting the invalidity of the patent.

The second is linked to the *preliminary* nature of the assessment in the PI proceedings, where the need for a swift decision seems to take precedence over an in-depth inquiry (which may be reserved for subsequent proceedings on the merits), so that the order does not need to fully reconstruct the case in all its legal or technical aspects, but rather only establish and explain, weighing up the competing interests and conducting a straightforward evaluation of the evidence, whether the conditions for granting interim relief are met under the given time constraints. Any other assessment should be dealt with in the proceedings on the merits.

The third consideration arises from the fact that the patent seems to be subject to amendments: EOFLOW's objections based on prior-art documents that were not addressed in the EPO research, have prompted the applicant to strive for a more detailed explanation of the technical characteristics of the "Omnipod5" and to make amendments to the PI claims. This will be discussed in more detail below.

INSULET amended the claims in its submission of 27 August 2024 and then in its submission of 16 September 2024.

The amendments may be summarized as follows (with modifications in bold):

AUXILIARY REQUEST 1: to refrain from manufacturing, offering, placing on the market, using or possessing.... a fluid delivery device comprising: a fluid reservoir, a transcutaneous access tool fluidly coupled to the fluid reservoir and a drive mechanism for actuating fluid from the fluid reservoir, the drive mechanism comprising: a drive wheel, a plunger received in the reservoir and a lead screw extending from the plunger, characterized in that the drive mechanism also comprises: a threadable **tube nut** with the lead screw and a clutch coupled to the drive wheel - wherein the clutch is configured to allow the **tube nut** to pass through the clutch when disengaged and is configured to grip the **tube nut** when engaged so that the drive wheel rotates the **tube nut** to advance the lead screw and plunger into the reservoir, **wherein the clutch mechanism includes a clutch spring that grips the tube nut when released;**

AUXILIARY REQUEST 2

- wherein the clutch is configured to allow the tube nut to pass through the clutch when disengaged and is configured to grip the tube nut when engaged so that the drive wheel rotates the tube nut to advance the lead screw and plunger into the reservoir, wherein the clutch mechanism includes a clutch spring that grips the tube-nut when released, and **wherein the clutch mechanism further also includes a spring latch configured to hold the clutch spring in a disengaged position and configured to release the clutch spring so that the spring moves to an engaged position.**

AUXILIARY REQUEST 3

- **wherein the clutch mechanism is configured to allow the tube nut to pass through the clutch mechanism when disengaged such that when the reservoir is filled, the plunger moves to the retracted end of the reservoir, and is configured to grip the tube nut when engaged, so that the drive wheel rotates the tube nut to advance the guide leadscrew and plunger into the reservoir, wherein the clutch mechanism includes a helical torsion spring that grips the tube nut when released.**

AUXILIARY REQUEST 4

- **wherein the clutch mechanism is configured to allow the tube nut to pass through the clutch mechanism when disengaged, such that when the reservoir is filled, the plunger moves towards the retracted end of the reservoir, and is configured to grip the tube nut when engaged, such that the drive wheel rotates the tube nut to advance the lead screw and plunger into the reservoir, wherein the clutch mechanism includes a helical torsion spring that grips the tube nut when released, wherein the helical torsion spring is located in a counter bore at one end of the drive wheel adjacent to the reservoir.**

These auxiliary requests combine the features of the granted requests 1 and 3, introducing numerous specifications (i.e. that the nut is a “tube nut” and that the clutch mechanism includes a spring that grips the “tube nut” when released, etc).

This Court therefore questioned, even in light of EOFLOW's plea of inadmissibility, whether these amendments should be considered amendments to the patent claims and thus fall within the scope of Rule 30 RoP or whether they were, as the claimant seemingly argued, mere amendments to the pleadings (legal requests) in the limited framework of the Preliminary injunction falling within limited scope of Rule 263 RoP.

The question was also put to the parties by the Panel during the oral hearing. The claimant appears to have framed them as modifications of the pleadings.

The difference does not appear to be irrelevant.

Rule 263 RoP specifies that a *‘party may at any stage of the proceedings apply to the Court for leave to change its claim or to amend its case, including adding a counterclaim. Any such application shall explain why such change or amendment was not included in the original pleading’*.

The rule seems to refer to amendments to the pleadings.

This interpretation can be inferred from several elements:

- firstly, the rule is included in the “*General Procedural Provisions*”, which, combined with a systematic interpretation, and the consideration that substantial amendments to patent claims are already addressed in Rule 30 RoP, suggests that these amendments may concern only the legal requests;
- the reference to ‘*amend the case*’ unambiguously supports this interpretation. Rule 30 RoP, by contrast, explicitly state “*amend the patent*”. It therefore appears that, also under a literal interpretation, the two amendments (Rules 30 and 263 RoP) may have two different objects.
- furthermore, if a party required to provide justification, under the threat of inadmissibility, for why an amendment had not been lodged in a timely manner, this provision clearly falls outside the scope of patent amendments where reference is made to requirements of Rules 84 and 123(2), (3) EPC. It is a well-established principle that the patentee may amend the patent claims (Art. 123 EPC) including during litigation. Deficiencies in the claims, as well as in the description, are reflected in possible limitations to the scope protected by the patent²; issues arising from patent claim modification pertain rather to a possible extension of patent protection. In such cases the timeliness of the amendment does not play a significant role.

By contrast, timeliness is relevant in Rule 263 ROP also in the light of the ‘parity of arms’ (see UPC_CFI 15/23: “*the claim for information serves inter alia to obtain information on the distribution channels of the infringing embodiment and the quantities and prices of the products delivered. Furthermore, the identity of third parties involved in the distribution of the infringing embodiment is of particular relevance to Edwards in order to effectively enforce its exclusive rights. The late amendments must be rejected in accordance with the aforementioned rationale*”).

The Court holds, therefore, that Rule 263 RoP refers only to amendments to pleadings and that Rule 30 RoP should be applicable, specifically, to patent amendments.

Starting from this point, it becomes evident that the amendments proposed by the applicant (quoted in bold above) do not constitute amendments to the pleadings but rather amendment to the patent, as the different wording clearly pertains to the way in which the patent operates.

In light of these considerations, the proposed amendments do not appear to be admissible, as they do not appear to be amendments to the legal requests as such, but instead involve substantial changes to the patent claims.

Even if considering them as mere amendments to the pleading, as argued by INSULET, under Rule 263(a) RoP “*the amendments in question could not have been made earlier with reasonable diligence*”, they remain inadmissible, as the applicant formally proposed them approximately three

² See UPC_CFI 114/24 “Finally, the claimant overlooks the fact that its amendments to the main applications also lead to an extension of the subject matter of the dispute with regard to the related applications in section III. In this respect, the claimant already justifies its extension which should therefore be rejected for this reason alone”.

weeks after raising them informally, a delay which cannot be consistent with reasonable diligence given the urgency of the proceedings.

As a general consideration, this Court is skeptical about whether, such pleading amendments can be proposed during interim proceeding which, as stated above, by their very nature, impose a sacrifice of procedural rights by the parties involved.

Protective measures, in fact, by their very nature are not necessarily intended to be durable and therefore do not seem well-suited to accommodating patent amendments.

Furthermore, allowing the patentee to modify the patent claim in PI proceedings where there's no risk of patent revocation, would give the party an unreasonable procedural advantage over the other party since, in the absence of any risk of a ruling on patent invalidity, the patentee would exploit the process to tailor the patent claim in the most appropriate way to address the issue of infringement.

Moreover, it seems appropriate to ensure that a PI does not merely become a condensed version - in a more limited timeframe - of the normal proceedings. It therefore seems reasonable, on the one hand, that an amendment of the patent should preferably occur during regular proceedings, where the validity of the patent can be more accurately assessed and definitively ascertained.

Turning back to the merits, as previously stated, it seems pertinent to conduct a preliminary assessment of the validity of EP4201327.

The 'sufficient degree of certainty' referred to in Rule 211.2 RoP requires the court to determine if it is at least more likely than not that the applicant has the right to initiate proceedings and that the patent has been infringed. A sufficient degree of certainty is (at least) lacking, if on the balance of probabilities, the court finds more likely than not that the patent is invalid.

EOFLOW has presented two prior art documents to this Court, which in its view appear destructive in view of EP4201327 validity.

The Court's examination focused on patent no. US 2009/0124994 (ROE US201261618028 US'994 in suit), which appears to bear the closest resemblance to EP4201327.

A) THE PATENT AT ISSUE

The patent at issue, EP 4201327, filed on 29 March 2013, claims priority from 30 March 2012 (US201261618028). The date of publication of the grant of the patent at issue is 19 June 2024.

The patent at issue relates to fluid delivery devices for delivering therapeutic liquids to a patient, and more particularly, to an infusion pump for delivering therapeutic liquids to a patient (cf. patent at issue, paragraph [0001]).

According to the description of the patent at issue, fluid delivery devices have numerous uses such as delivering a liquid medicine or other therapeutic fluid to a patient subcutaneously. In a patient with diabetes mellitus, for example, ambulatory infusion pumps have been used to deliver insulin to a patient. The ability to carefully control drug delivery can result in better efficacy of the drug and therapy and less toxicity to the patient. (cf. patent at issue, paragraph [0002]). Although prior art

pumps are effective and provide several advantages, the fluid driving mechanism may also be improved to facilitate assembly and use of the pump (cf. patent at issue, paragraph [0004]).

B) THE TECHNICAL PROBLEM

In view of this, the substantial problem underlying the patent at issue can be seen in providing a fluid delivery device where the filling of the fluid reservoir is simple and changing the device into a state for delivering fluid to a patient is efficient and reliable (cf. patent at issue, paragraph 0008)³.

C) THE PERSON SKILLED IN THE ART

At the oral hearing, the parties agreed to define the expert in the field as ‘a person skilled in the art who possesses at least a degree in mechanical engineering, or an equivalent degree, with several years of experience in the design and manufacture of medical devices, in particular in small mechanics. On this basis, the person skilled in the art should have understood the basics of medical device design and manufacturing and the basic mechanical elements (e.g., gears, pistons) involved in drug delivery devices. The Court also agrees with this definition.

D) CLAIM CONSTRUCTION AND CLAIM INTERPRETATION

According to claim 1 of the patent at issue, the problem addressed in the patent at issue is resolved through the following product:

1	A fluid delivery device comprising:
2	a fluid reservoir (130);
3	a transcutaneous access tool (172) fluidly coupled to the fluid reservoir (130); and
4	a drive mechanism (150) for driving fluid from the reservoir (130), the drive mechanism comprising
4.1	drive wheel (156; 256);
4.2	a plunger (136) received in the reservoir (130); and
4.3	a leadscrew (152) extending from the plunger (136); characterized in that the drive mechanism (150) further comprises:
4.4	a nut (154) threadably engaged with the leadscrew (152); and

³ Technical problem is also described under 0004 “Some infusion pumps have been designed to be relatively small low-cost lightweight and easy to use, one example of such a pump is the Omnipod insulin infusion pump available from INSULET corporation. These pumps include insertion mechanism for causing a transcutaneous access tool such as a needle and a soft cannula to be inserted into a patient; although such pumps are effective and provide significant advantages over other insulin infusion pumps the design of the insertion mechanism may be improved to reduce the size of the pump, to improve the comfort to the user and to incorporate continuous glucose monitoring”.

4.5	a clutch mechanism (160) coupled to the drive wheel (156; 256),
4.5.1	wherein the clutch mechanism (160) is configured to allow the nut (154) to pass through the clutch mechanism (160) when disengaged and
4.5.2	is configured to grip the nut (156) when engaged such that the drive wheel (156; 256) rotates the nut (156) to advance the leadscrew (152) and the plunger (136) into the reservoir (130).

Claim feature 4.5.1 requires special consideration and should be read in connection with claim features 4, 4.1 to 4.5 and 4.5.2. These features relate specifically to the arrangement of components of the nut (154) with respect to the clutch mechanism (160):

Features 4, 4.1 and 4.2: A drive mechanism (150) for driving fluid from the reservoir (130) of the fluid delivery device comprises a drive mechanism, a drive wheel (156; 256), and a plunger (136) received in the reservoir (130).

Features 4.3 and 4.4: A leadscrew (152) extending from the plunger (136); a nut (154) is threadably engaged with the leadscrew (152).

Features 4.5, 4.5.1 and 4.5.2: A clutch mechanism (160) is coupled to the drive wheel (156; 256). The clutch mechanism (160) is configured to allow the nut (154) to pass through the clutch mechanism (160) when disengaged (feature 4.5.1). According to feature 4.5.2 the clutch mechanism is configured to grip the nut (156) when engaged such that the drive wheel (156; 256) rotates the nut (156) to advance the leadscrew (152) and the plunger (136) into the reservoir (130).

These features teach the skilled person, that the drive wheel (156) can rotate the nut, as the clutch mechanism is coupled to the drive wheel and the clutch mechanism engages the nut (cf. patent at issue, Fig. 12 and Fig. 16). This means that the clutch mechanism may initially be disengaged and thus not grip the nut so that the nut can pass through the clutch mechanism without rotation of the drive wheel (cf. feature 4.5.1).

A note on Fig. 12 and Fig. 16. Fig. 12 shows an embodiment, where the reservoir (130) is not filled with fluid. In Fig. 16, the device is shown with a plunger (136) in a position associated with a filled reservoir (130). Fig. 16 illustrates a removed drive wheel (156) and shows details of the clutch

mechanism (160) (cf. patent at issue, paragraph [0020]).

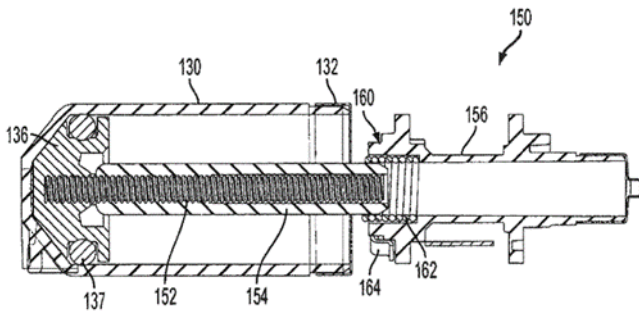

FIG. 12

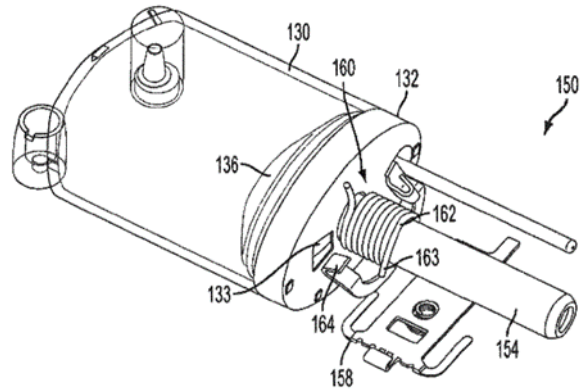
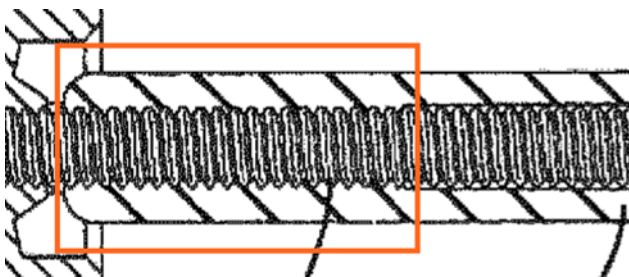
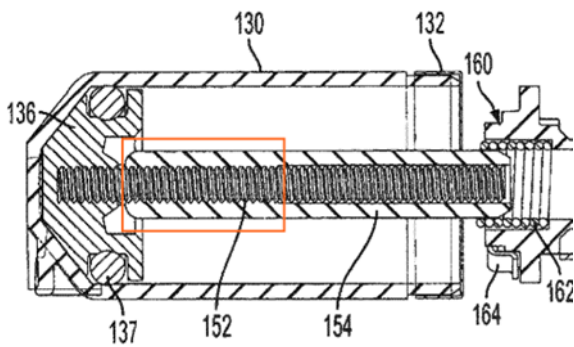

FIG. 16

In general, the skilled person understands a nut to be a hollow body with a thread on its inner surface. According to an embodiment/example illustrated in Figure 12, the nut (154) is an elongated tube nut in which one part of the nut has an internal thread (left part of nut 154; see marked section enlargements of Fig. 12 below) and another elongated part is only a tube or cylinder without any thread (right part of nut 154).



In feature 4.5.1, to “allow the nut (154) to pass through the clutch mechanism (160)” does not necessarily mean that the (elongated) nut or its internal thread has to pass entirely through the clutch mechanism. Furthermore, it is not necessary for the clutch mechanism to grip the part of the elongated nut that has a thread (cf. patent at issue, Figs. 12 and 16, see the length of the parts/components of the device).

E) VALIDITY OF THE PATENT AT ISSUE IN VIEW OF THE PRIOR ART US'994 (ROE)

The validity of the patent at issue is uncertain for the purpose of RoP 211.1 in view of US'994.

US'994 describes a fluid delivery device (delivery pump 40) that comprises a fluid (liquid) reservoir represented by a liquid drug container (drug container 46) in accordance with features 1 and 2 (cf. Abstract, exploded view Fig. 4 and paragraph [0022]: [...] dispense a liquid drug from a drug container 46).

The two devices concern the same technology, related to small-sized fluid delivery devices for administrating fluids to a patient.

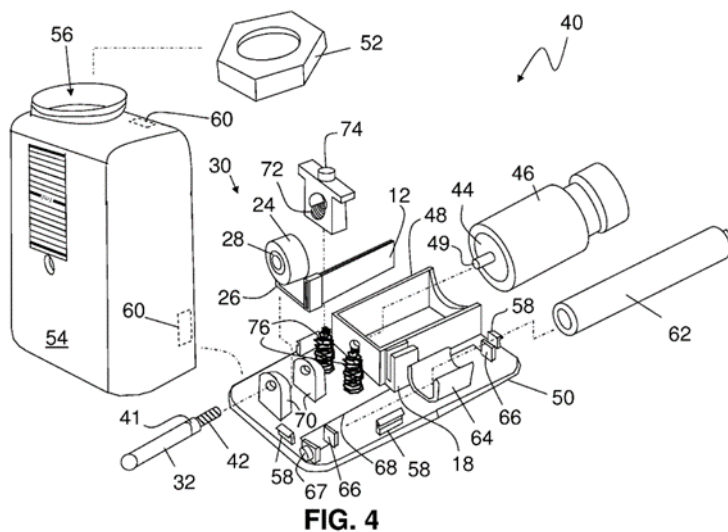

FIG. 4

This device contains an administration set 98 serving as a transcutaneous access tool, which is fluidly coupled to the fluid reservoir (drug container 46), as shown in Fig. 6 (cf. Paragraphs [0030]: The drug container 46 includes an injection site 94 which is used to connect a spike or other suitable type of connector 96 of an administration set 98 to the delivery pump 40. The spike or other suitable type of connector 96 is connected to a fluid conduit 100 [...] / feature 3).

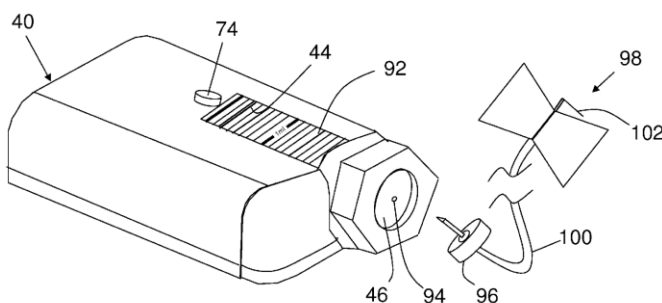
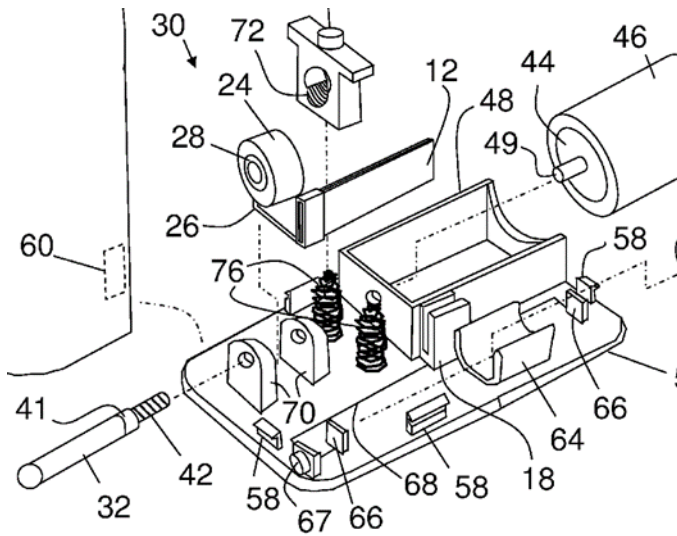

FIG. 6

A drive mechanism of the device comprises a lead screw (42) extending from a plunger or piston (44), a corresponding (elongated) nut (41) with a shaft (32) and threads (not shown), and a clutch (28) coupled to a drive wheel (24) in order to drive fluid (liquid drug) from the reservoir (drug container

46) in accordance with features 4, 4.1 to 4.4 (cf. exploded view Figs. 4 and paragraphs 20-22), The aforementioned elongated nut 41 with a shaft 32 and threads represents a tube nut similar to the tube nut of the patent at issue.



The piezoelectric drive in Us'994 operates by using a clutch (28) that alternatively engages and disengages a tube-nut connected to a shaft (41 and 32 respectively) and a lead screw (42) combination to push a piston (plunger 44) into the reservoir (46) to administer a fluid.

As previously mentioned, a clutch mechanism (clutch 28) is coupled to a wheel (wheel 24) which serves as a drive wheel of the device (feature 4.5). The clutch mechanism (clutch 28) is also configured to allow the nut (nut portion 41) with its shaft (shaft 32) to pass through the clutch mechanism when disengaged (cf. Fig. 4-5, paragraphs [0021] and [0022]: [...] a nut portion (41) is provided at the open end of the cavity (33) of the shaft (32). The threads (not shown) of the nut portion (41) engage the threads of the lead screw (42) and cause the movement of the lead screw (42) upon rotation of the shaft (32). Movement of the lead screw (42) advances a plunger or piston 44 to dispense a liquid drug from a drug container 46). This means that feature 4.5.1 seems to be already present in the device known from the prior art according to US'994, Exhibit BB02.

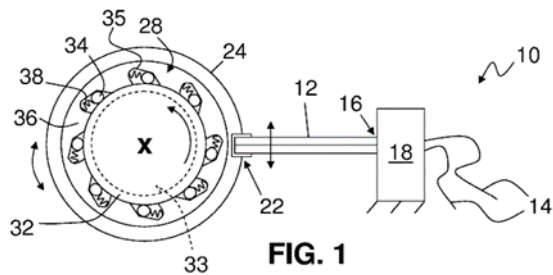

FIG. 1

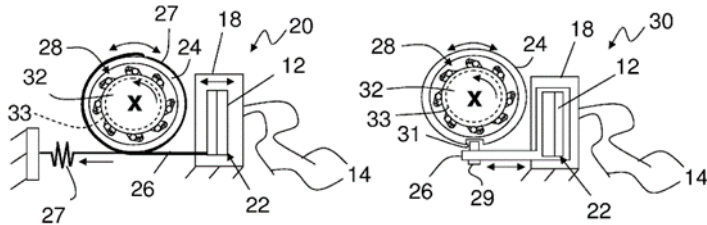

FIG. 2

FIG. 3

The clutch mechanism is configured to grip the nut (shaft 32 of the elongated nut 41) when engaged such that the drive wheel (wheel 24) rotates this nut and its threads (threads (not shown) of the nut portion 41) advance the leadscrew (lead screw 42) by engaging the threads of the leadscrew (threads of the lead screw 42). This advances the connected plunger (plunger or piston 44) into the reservoir (drug container 46) to dispense the liquid drug (cf. Figs. 1-5 and paragraph 22: Movement of the lead screw 42 advances a plunger or piston 44 to dispense a liquid drug from a drug container 46 / feature 4.5.2).

And thus US 994' seems to have disclosed all features claimed in EP 327:

- a fluid delivery device (feature 1 – disclosed in Fig. 4 and 6 of 'US 994),
- a fluid reservoir (feature 2 disclosed in paragraph 22 of US'994),
- a transcutaneous access tool (172) fluidly coupled to the fluid reservoir (130) (feature 3 disclosed in Fig. 6 and in paragraph 30 of US'994, being to this extent irrelevant whether the reservoir is always coupled to the needle or only when in use),
- a drive mechanism (150) for driving fluid from the reservoir (130) (feature 4) the drive mechanism comprising a drive wheel (feature 4.1 present as '24' in US'994 and described in paragraph 18 "driven by a piezoelectric bender"), a plunger (feature 4.2. marked 44 in US'994) a leadscrew (marked 42 in US'994) extending from the plunger (44 in US'994), a nut (marked 41 in US '994) threadably engaged with the leadscrew (disclosed in Fig. 5 and in paragraph 22 of US'994 'the movement of the leadscrew 42 advances a plunger or piston 44') and a clutch mechanism (feature 4.5, marked 28 in US'994 and coupled to drive wheel 24) coupled to the drive wheel (see also paragraph 20 of Us'994), wherein the clutch mechanism (feature 4.5.1.) is configured to allow the nut (154) to pass through the clutch mechanism (160) when disengaged (see Fig. 4 of US'994 'threaded nut portion 41 and part of the shaft 32 pass through the clutch 28) and is configured to grip the nut (Feature 4.5.2) when engaged such that the drive wheel (156; 256) rotates the nut (156) to advance the leadscrew (152)

and the plunger (136) into the reservoir (*likely disclosed in Fig.4 of Us'994 where the clutch 28 is configured to grip the shaft 32 with clutch rollers 34*).

However, based on these significant similarities, and in light of the criteria of Art. 211 RoP and in particular the likelihood of the patent validity, and bearing in mind the fair balancing of the competing interests of the parties, the Court holds that the requisites for issuing the requested injunction are not present.

Regarding the balancing of the parties' positions, the Court considers also the already filed invalidity claim, which is destined to be concluded in a reasonable timeframe and the potential harm for the defendant resulting from inhibiting the distribution and sale of the embodiment.

E1) INSULET OBSERVATIONS

INSULET rebutted to these observations (summarized in Prof. Pott's opinion in Exh. N. 4) emphasizing the differences between '327 and 'US 994.

INSULET asserts that the subject-matter of granted claims 1 to 5 of the patent at issue is still to be considered novel and inventive also in view of the document US'994 provided that:

- US'994 does not comprise feature 4.5.1. (*wherein the clutch mechanism (160) is configured to allow the nut (154) to pass through the clutch mechanism (160) when disengaged*), whereas the tube-nut in US '994 should entirely pass throughout the clutch,
- the embodiment in Figure 5 does not disclose feature 4.4 (*a nut (154) threadably engaged with the leadscrew*) and thus US'994 would not disclose a threadably engagement at all,
- the teaching of '994 is not workable because of the threads (80) in keyhole (72) would prevent the mobility of the shaft and because the clutch (28) fixed to the base (70) would prevent any movement of both tube-nut and shaft.

INSULET understands US'994 as disclosing a piezoelectric bender (12) which moves the wheel (24) stepwise in counterclockwise direction and in clockwise direction (Figs. 1 - 3). The one-way clutch (28) rotates shaft (32) only in one direction (in Figure 1 only in counterclockwise direction) so that US'994 does not disclose a longitudinal movement of the shaft (32) at all, mostly in the mounted state of the drug delivery device, since the shaft (32) would be (fixedly) supported by a pair of base supports (70), and Fig. 4 (supports have been marked yellow):

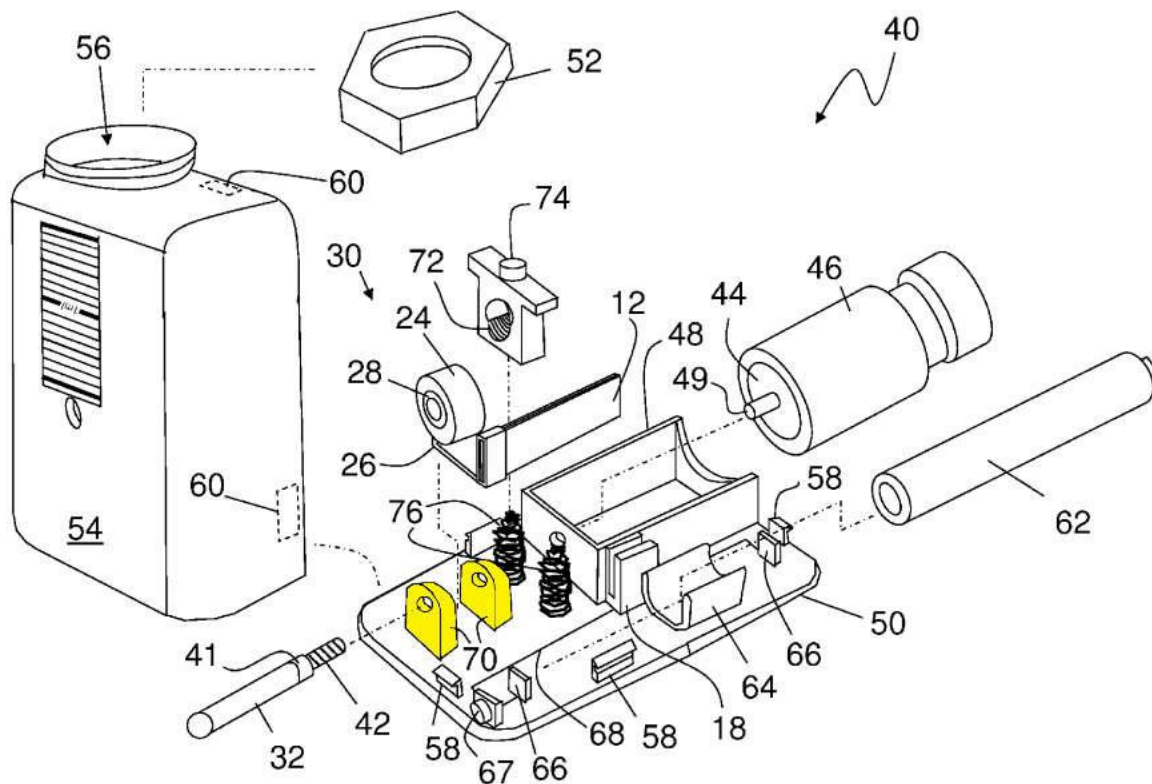

Furthermore, the shaft (32) would not move in longitudinal direction. When the wheel (24) rotates the shaft (32) in counterclockwise direction (as shown in Figs. 1 - 3), the one-way clutch mechanism (28) would lock the shaft over its clutch rollers (34), i.e. a longitudinal movement is not possible, as confirmed in the description in point 21 *“As the wheel 24 rotates in the counter-clockwise direction, clutch rollers 34 jam between the shaft 32 and the clutch body 36, locking them together.”*

Moreover, in the embodiment of Figure 5 – continues INSULET - the shaft does not have an internal thread. Instead, the leadscrew 42 is slidably accommodated in a cavity (33) of the shaft (see US’994, para.[0028]). A detent portion (84) is provided inside this cavity (33) which engages a slot (86) provided in the leadscrew (42) (see para. [0028] and Fig. 5). Therefore, the shaft (32) rotates together with the leadscrew (42), but does not transmit a longitudinal/axial force to the leadscrew (42). The rotation of the leadscrew (42) is transmitted into a longitudinal movement due to the engagement of the external thread of the leadscrew (42) with the thread (80) in the keyhole (72) of the release button (74).

Finally, the skilled person would recognize in US’994 that the teaching of this embodiment is technically not feasible/workable and contains an obvious error: a rotation of the leadscrew (42) is also intended to be transitioned into a longitudinal movement due to the engagement of its thread with the thread in the keyhole (72) of the release button (74) (see US’994, para. [0027] and Fig. 4)⁴.

⁴ As the shaft (32) rotates the leadscrew (42) it could be assumed – according to a first theory – that the leadscrew (42) is fixedly connected to the shaft (32) over the nut portion (41) (which end in a blind hole), i.e. the leadscrew cannot move in axial/longitudinal direction relative to the shaft (32). Therefore, the leadscrew (42) is fixedly screwed into the

INSULET's objections do not stand up to a factual analysis of the patent.

US'994 describes two screw mechanisms which are responsible for advancing a lead-screw (in figures 4 and 5 respectively), which differ only by the system of converting a rotational motion into a longitudinal motion: these mechanism can be described respectively as 'non-rotating nut' and 'rotating nut'.

US'994 describes – therefore - two features of its delivery pump, both based on a freewheeling system that transmits rotation in only one direction as shown in figure n. 3 below:

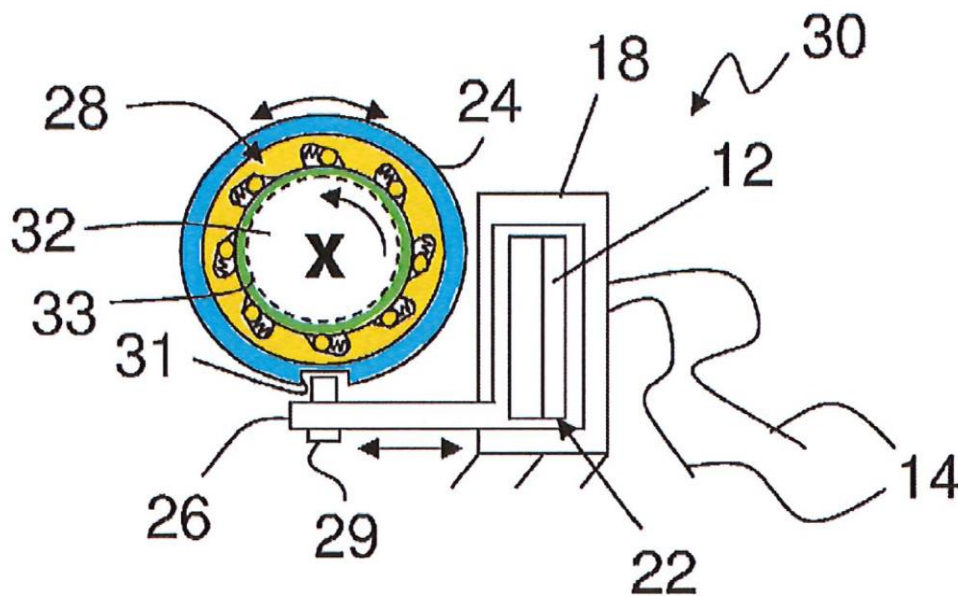

FIG. 3

There is no evidence that in US'994 the leadscrew (42) connected to the shaft (32) over the tube-nut (41) has to pass completely through the clutch (28), during or before the filling, since there is no apparent benefit or advantage associated with the plunger (44) being shifted to the retracted position during the filling process⁵; nor, logically, does the clutch (28) need to be fixedly attached to

(very short) nut portion (41) such that both parts together form a single unit. However, in this case, the drive system would block itself: when the wheel (24) rotates the shaft (32), the one-way clutch mechanism (28) locks the shaft over its clutch rollers (34) (see US'994, para. [0021], third sentence: "[...] clutch rollers 34 jam between the shaft 32 and the clutch body 36, locking them together."). This locked state would prohibit any relative movement between the wheel (24) and the shaft (32). In addition, the shaft (32) is (fixedly) supported by a pair of base supports (70).

⁵ It was amply clarified during the oral hearing and from the reading of Exhibit n. 4 (Prof. POTT's Opinion) that it is irrelevant whether the leadscrew is threaded for its entire length or for a part since the thread fulfils a function only to the extent that it is involved in the clutch. In general, the skilled person understands a nut to be a hollow body with a thread on its inner surface. The skilled person also understands that, as to claim 4.5.1. when it goes about the nut passing

the base (70): the word ‘supported’ used in the description does not allow an interpretation (fixed) that contradicts the functionality of the mechanism. Patent claims should not be read in a way that technically contradicts the description.

There is also no basis neither in US’994 claims, nor in the description, to assert that that shaft (32) and leadscrew (42) should rotate together⁶.

Both mechanisms can be summarily described as working alternatively through “rotating nut” (fig. 4) and “non-rotating nut” (fig. 5), whereas in the latter it is the screw to rotate inside the nut. But both examples show the conversion of a rotation motion into a translational motion, which is the ultimate purpose of the mechanism. They are well-known alternatives in the field of mechanical engineering and an expert in the filed would be capable of understanding the differences between them.

See figure 4 and 5 (below) (the first two pictures are taken from Peter Pott’s Opinion Exh. N. 4), the first one performing a “non-rotating screw” the second one performing a “rotating screw”:

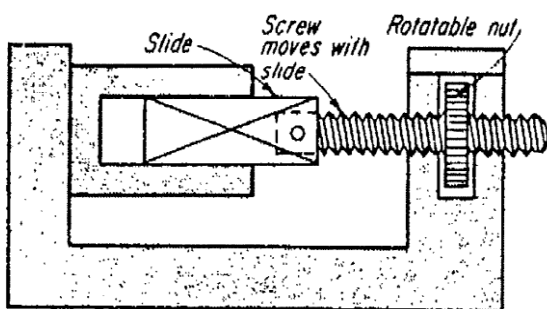

NON-ROTATING SCREW/ROTATING NUT

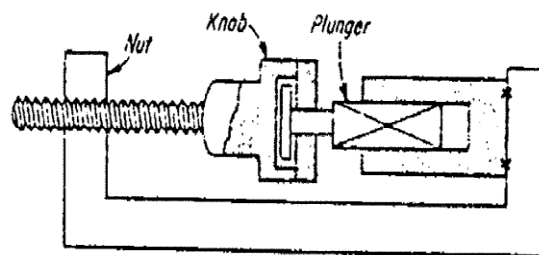

NON-ROTATING NUT/ ROTATING SCREW

through the clutch mechanism, it does not necessarily mean that the (elongated) nut or its internal thread has to pass entirely through the clutch.

⁶ According to the case law of the UPC Court of Appeal (Order of 26 February 2024 - UPC_CoA_335/2023 pp_576355/2023, NanoString Technologies et al. v 10x Genomics et al, GRUR 2024 para. 73 et seq.; Order of 13 May 2024 - UPC_CoA_1/2024 APL_8/2024 para. 26) according to Art. 69 EPC and the Protocol on its Interpretation (Protocol on Interpretation) the following principles: The patent claim is not only the starting point, but the relevant basis for determining the scope of protection of the European patent. The interpretation of a patent claim does not depend solely on its exact wording in the linguistic sense; rather, the description and the drawings must always be taken into account as explanatory aids for the interpretation and not only be used to eliminate any ambiguities in the patent claim.

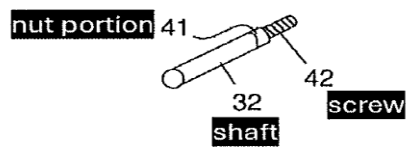

screw-nut in Fig. 4

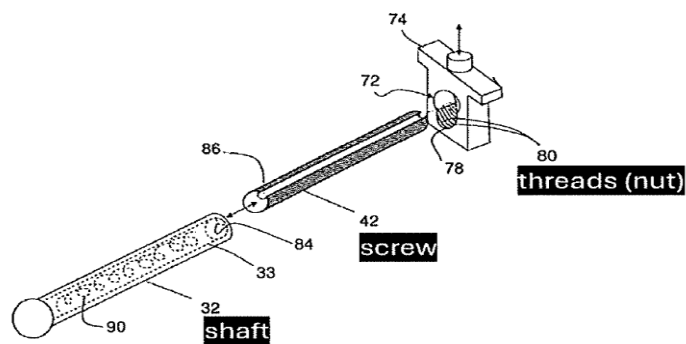

screw-nut in Fig. 5

In Fig. 4 of Roe, the screw 42 is connected to the nut portion 41 of the shaft 32, see para. [0022]:

INSULET further objects that US'994 does not describe a longitudinal movement of the shaft at all (32): in Figure 4) the screw (42) is connected to the nut portion (41) on the shaft (32) (see. Paragraph 22), so that when the threaded nut, the nut portion (41) in Fig. 4 is rotating, the screw does not rotate and is driven to advance translationally throughout a snap-in connection (49) to the piston (44). The shaft (32) of US'994 needs therefore to be rotatable.

The Court observes that the shaft (32) is only supported in the operational phase; on the contrary, in the rotation and assembly mode the shaft (32) is 'supported' by the base (70) but not fixed to it, because it needs to rotate when the clutch (28) is activated, so that the embodiment seems to be fully workable. The use in the patent description of the term "support' and not 'fix' seems to be consistent and makes the device workable rather than not.

On the other hand, it is a general principle (as already previously mentioned) that the patent description must be interpreted according to the sense that makes the invention workable rather than not. This explains also why the shaft (32) does not have to "retract back", a feature which would make the device unworkable, and which clearly refers only to the "rotating screw" in model Fig. 5) and not the one in Fig. 4) described just now.

Similarly, the keyhole (72) is relevant within US'994 almost exclusively in relation to the non-rotating nut mode depicted in figure 5). A skilled reader would understand that the release button (74) play a role only when the shaft-screw is used.

INSULET claims nevertheless that the threaded part (80) of the keyhole (72) would engage with the screw (42) getting the device stuck. Prof. Pott's opinion (Exhibit n. 4) at page 22 ff. explains why the threaded keyhole (72) is only for the purpose of the embodiment featured in Fig. 5); moreover, he explains that the serial industrial production of the embodiment (in the two forms shown in Fig. 4 and 5) could also lead to maintain the keyhole (72) also in the rotating mode as redundant part to facilitate the differentiation only in the operational phase

The Keyhole 72 could be realized also as not engaging without any leadscrew, either by dimensioning the parts as fully detached, or by keeping the release button (74) active. In no case this feature would definitively make the device 'non working'.

So even if at first glance, a release button (74) with the thread (78) in the base, as shown in Fig. 4 of US'994 might not appear to be compatible with the explanations in paragraph [0022] of US'994, however, this is resolved in the description of US'994 (cf. paragraph [0028], last sentence, Figs. 4 and 5). Accordingly, this configuration belongs clearly to a different embodiment in which there is no thread provided in the shaft (32) of the nut, instead a spring (90), pushes the lead screw (42) (connected to thread 78) and thus also the piston further into drug container (44).

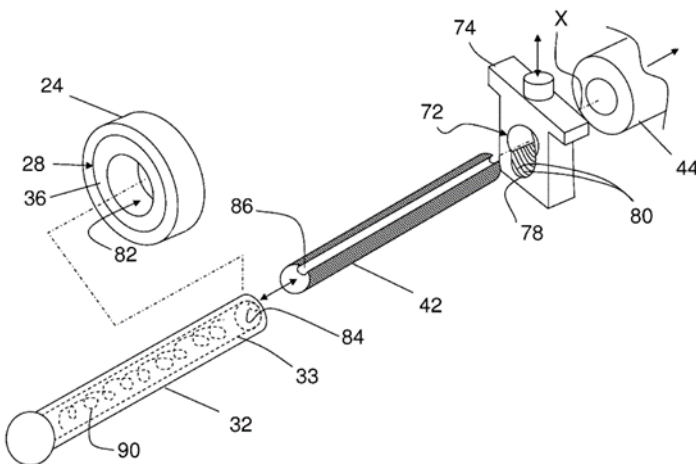

FIG. 5

Consequently, a person skilled in the art would identify two distinct embodiments in Figure 4 upon reading paragraph [0028], with no contradiction to the description provided in paragraph [0022] concerning the same Figure 4 of US'994.

Therefore, the US'994 does not contain any errors, nor are the embodiments "unworkable".

To encapsulate, the subject matter of claim 1 of '327 is unlikely to be considered novel in light of the prior art disclosed in US'994, as the fluid delivery device described in US'994 seem to incorporate all the features described in claim 1 of the patent at issue.

Doubts regarding patent validity appear to be preventing the issuance of the requested order.

The PI application must therefore be denied. Ancillary requests as well.

Applicant is required to bear cost of the proceedings pursuant to Art. 69 UPCA and Rule 118.5. RoP.

The cost ceiling is set in accordance with the scale of recoverable costs ceilings published by the Administrative Committee using the value of the case as indicated by the claimant (2.500.000 euros) as a benchmark.

FOR THESE REASONS

- The application for a preliminary injunction is rejected as well as the ancillary requests.

- The applicant is required to bear the costs of the litigation, The value in dispute is set at EUR 2,500,000.00. The ceiling for the reimbursable representation costs is set at EUR 400,000.00.

Milan 22 Novembre 2024

Presiding Judge

Andrea Postiglione

Technically qualified Judge

Uwe Schwengelbeck

Legally qualified Judge

Anna-Lena Klein

Order no. ORD_/2024 in ACTION NUMBER: Not provided

UPC number: UPC_CFI_380/2024

Related proceeding no. Application No.: 39640/2024

Application Type: Application for provisional measures (RoP206)